

BETASERON[®]

(INTERFERON BETA-1b) FOR SC INJECTION

DESCRIPTION

Betaseron[®] (Interferon beta-1b) is a purified, sterile, lyophilized protein product produced by recombinant DNA techniques. Interferon beta-1b is manufactured by bacterial fermentation of a strain of *Escherichia coli* that bears a genetically engineered plasmid containing the gene for human interferon beta_{ser17}. The native gene was obtained from human fibroblasts and altered in a way that substitutes serine for the cysteine residue found at position 17. Interferon beta-1b has 165 amino acids and an approximate molecular weight of 18,500 daltons. It does not include the carbohydrate side chains found in the natural material.

The specific activity of Betaseron is approximately 32 million international units (IU)/mg Interferon beta-1b. Each vial contains 0.3 mg of Interferon beta-1b. The unit measurement is derived by comparing the antiviral activity of the product to the World Health Organization (WHO) reference standard of recombinant human interferon beta. Mannitol, USP and Albumin (Human), USP (15 mg each/vial) are added as stabilizers.

Lyophilized Betaseron is a sterile, white to off-white powder, for subcutaneous injection after reconstitution with the diluent supplied (Sodium Chloride, 0.54% Solution).

CLINICAL PHARMACOLOGY

General

Interferons (IFNs) are a family of naturally occurring proteins, produced by eukaryotic cells in response to viral infection and other biologic agents. Three major groups of interferons have been distinguished: alpha, beta, and gamma. Interferons alpha and beta comprise the Type I interferons and interferon gamma is a Type II interferon. Type I interferons have considerably overlapping but also distinct biologic activities. The bioactivities of IFNs are mediated by their interactions with specific receptors found on the surfaces of human cells. Differences in bioactivities induced by IFNs likely reflect divergences in the signal transduction process induced by IFN-receptor binding.

Biologic Activities

The mechanism of action of Interferon beta-1b in patients with multiple sclerosis is unknown. Interferon beta-1b receptor binding induces the expression of proteins that are responsible for the pleiotropic bioactivities of Interferon beta-1b. A number of these proteins (including neopterin, β_2 -microglobulin, MxA protein, and IL-10) have been measured in blood fractions from Betaseron-treated patients and Betaseron-treated healthy volunteers. Immunomodulatory effects of Interferon beta-1b include the enhancement of suppressor T cell activity, reduction of pro-inflammatory cytokine production, down-regulation of antigen presentation, and inhibition of lymphocyte trafficking into the central nervous system. It is not known if these effects play an important role in the observed clinical activity of Betaseron in multiple sclerosis (MS).

Pharmacokinetics

Because serum concentrations of Interferon beta-1b are low or not detectable following subcutaneous administration of 0.25 mg or less of Betaseron, pharmacokinetic information in patients with MS receiving the recommended dose of Betaseron is not available. Following single and multiple daily subcutaneous administrations of 0.5 mg Betaseron to healthy volunteers (N=12), serum Interferon beta-1b concentrations were generally below 100 IU/mL. Peak serum Interferon beta-1b concentrations occurred between one to eight hours, with a mean peak serum interferon concentration of 40 IU/mL. Bioavailability, based on a total dose of 0.5 mg Betaseron given as two subcutaneous injections at different sites, was approximately 50%.

After intravenous administration of Betaseron (0.006 mg to 2.0 mg), similar pharmacokinetic profiles were obtained from healthy volunteers (N=12) and from patients with diseases other than MS (N=142). In patients receiving single intravenous doses up to 2.0 mg, increases in serum concentrations were dose proportional. Mean serum clearance values ranged from 9.4 mL/min•kg⁻¹ to 28.9 mL/min•kg⁻¹ and were independent of dose. Mean terminal elimination half-life values ranged from 8.0 minutes to 4.3 hours and mean steady-state volume of distribution values ranged from 0.25 L/kg to 2.88 L/kg. Three-times-a-week intravenous dosing for two weeks resulted in no accumulation of Interferon beta-1b in sera of patients. Pharmacokinetic parameters after single and multiple intravenous doses of Betaseron were comparable.

Following every other day subcutaneous administration of 0.25 mg Betaseron in healthy volunteers, biologic response marker levels (neopterin, β_2 -microglobulin, MxA protein, and the immunosuppressive cytokine, IL-10) increased significantly above baseline six-twelve hours after the first Betaseron dose. Biologic response marker levels peaked between 40 and 124 hours and remained elevated above baseline throughout the seven-day (168-hour) study. The relationship between serum Interferon beta-1b levels or induced biologic response marker levels and the clinical effects of Interferon beta-1b in multiple sclerosis is unknown.

CLINICAL STUDIES

The clinical effects of Betaseron were studied in four randomized, multicenter, double-blind, placebo-controlled studies in patients with multiple sclerosis.

The effectiveness of Betaseron in relapsing-remitting MS (Study 1) was evaluated in a double blind, multiclinic, randomized, parallel, placebo controlled clinical investigation of two years duration. The study enrolled MS patients, aged 18 to 50, who were ambulatory (EDSS of ≤ 5.5), exhibited a relapsing-remitting clinical course, met Poser's criteria¹ for clinically definite and/or laboratory supported definite MS and had experienced at least two exacerbations over two years preceding the trial without exacerbation in the preceding month. Patients who had received prior immunosuppressant therapy were excluded.

An exacerbation was defined as the appearance of a new clinical sign/symptom or the clinical worsening of a previous sign/symptom (one that had been stable for at least 30 days) that persisted for a minimum of 24 hours.

Patients selected for study were randomized to treatment with either placebo (N=123), 0.05 mg of Betaseron (N=125), or 0.25 mg of Betaseron (N=124) self-administered subcutaneously every other day. Outcome based on the 372 randomized patients was evaluated after two years.

Patients who required more than three 28-day courses of corticosteroids were removed from the study. Minor analgesics (acetaminophen, codeine), antidepressants, and oral baclofen were allowed ad libitum, but chronic non-steroidal anti-inflammatory drug (NSAID) use was not allowed.

The primary protocol-defined outcome measures were 1) frequency of exacerbations per patient and 2) proportion of exacerbation free patients. A number of secondary clinical and magnetic resonance imaging (MRI) measures were also employed. All patients underwent annual T2 MRI imaging and a subset of 52 patients at one site had MRIs performed every six weeks for assessment of new or expanding lesions.

The study results are shown in **Table 1**.

TABLE 1
Two Year RRMS Study Results
Primary and Secondary Clinical Outcomes

Efficacy Parameters	Treatment Groups			Statistical Comparisons			
	Placebo (N=123)	0.05 mg (N=125)	0.25 mg (N=124)	Placebo vs 0.05 mg	0.05 mg vs 0.25 mg	Placebo vs 0.25 mg	
Primary End Points							
Annual exacerbation rate	1.31	1.14	0.90	0.005	0.113	0.0001	
Proportion of exacerbation-free patients†	16%	18%	25%	0.609	0.288	0.094	
Exacerbation frequency per patient	0†	20	22	29	0.151	0.077	0.001
	1	32	31	39			
	2	20	28	17			
	3	15	15	14			
	4	15	7	9			
	>5	21	16	8			
Secondary Endpoints††							
Median number of months to first on-study exacerbation	5	6	9	0.299	0.097	0.010	
Rate of moderate or severe exacerbations per year	0.47	0.29	0.23	0.020	0.257	0.001	
Mean number of moderate or severe exacerbation days per patient	44.1	33.2	19.5	0.229	0.064	0.001	
Mean change in EDSS score‡ at endpoint	0.21	0.21	-0.07	0.995	0.108	0.144	
Mean change in Scripps score‡‡ at endpoint	-0.53	-0.50	0.66	0.641	0.051	0.126	
Median duration in days per exacerbation	36	33	35.5	ND	ND	ND	
% change in mean MRI lesion area at endpoint	21.4%	9.8%	-0.9%	0.015	0.019	0.0001	

ND Not done

† 14 exacerbation free patients (0 from placebo, six from 0.05 mg, and eight from 0.25 mg) dropped out of the study before completing six months of therapy. These patients are excluded from this analysis.

†† Sequelae and Functional Neurologic Status, both required by protocol, were not analyzed individually but are included as a function of the EDSS.

‡ EDSS scores range from 1-10, with higher scores reflecting greater disability

‡‡ Scripps neurologic rating scores range from 0-100, with smaller scores reflecting greater disability.

Of the 372 RRMS patients randomized, 72 (19%) failed to complete two full years on their assigned treatments.

Over the two-year period, there were 25 MS-related hospitalizations in the 0.25 mg Betaseron-treated group compared to 48 hospitalizations in the placebo group. In comparison, non-MS hospitalizations were evenly distributed among the groups, with 16 in the 0.25 mg Betaseron group and 15 in the placebo

group. The average number of days of MS-related steroid use was 41 days in the 0.25 mg Betaseron group and 55 days in the placebo group (p=0.004).

MRI data were also analyzed for patients in this study. A frequency distribution of the observed percent changes in MRI area at the end of two years was obtained by grouping the percentages in successive intervals of equal width. Figure 1 displays a histogram of the proportions of patients, which fell into each of these intervals. The median percent change in MRI area for the 0.25 mg group was -1.1%, which was significantly smaller than the 16.5% observed for the placebo group (p=0.0001).

Distribution of Change in MRI Area
Figure 1

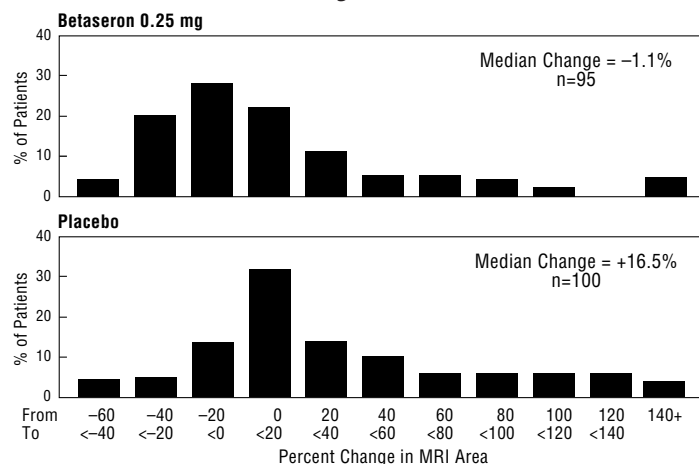

In an evaluation of frequent MRI scans (every six weeks) on 52 patients at one site, the percent of scans with new or expanding lesions was 29% in the placebo group and 6% in the 0.25 mg treatment group (p=0.006).

The exact relationship between MRI findings and clinical status of patients is unknown. Changes in lesion area often do not correlate with changes in disability progression. The prognostic significance of the MRI findings in this study has not been evaluated.

Studies 2 and 3 were multicenter, randomized, double-blind, placebo controlled trials conducted to assess the effect of Betaseron in patients with SPMS. Study 2 was conducted in Europe and Study 3 was conducted in North America. Both studies enrolled patients with clinically definite or laboratory-supported MS in the secondary progressive phase, and who had evidence of disability progression (both Study 2 and 3) or two relapses (Study 2 only) within the previous two years. Baseline Kurtzke expanded disability status scale (EDSS) scores ranged from 3.0 to 6.5. 2 Patients in Study 2 were randomized to receive Betaseron 0.25 mg (N=360) or placebo (N=358). Patients in Study 3 were randomized to Betaseron 0.25 mg (N=317), Betaseron 0.16 mg/m² of body surface area (N=314, mean assigned dose 0.30 mg), or placebo (N=308). Test agents were administered subcutaneously, every other day for three years.

The primary outcome measure was progression of disability, defined as a 1.0 point increase in the EDSS score, or a 0.5 point increase for patients with baseline EDSS ≥ 6.0. In Study 2, time to progression in EDSS was longer in the Betaseron treatment group (p=0.005), with estimated annualized rates of progression of 16% and 19% in the Betaseron and placebo groups, respectively. In Study 3, the rates of progression did not differ significantly between treatment groups, with estimated annualized rates of progression of 12%, 14%, and 12% in the Betaseron fixed dose, surface area-adjusted dose, and placebo groups, respectively.

Multiple analyses, including covariate and subset analyses based on sex, age, disease duration, clinical disease activity prior to study enrollment, MRI measures at baseline and early changes in MRI following treatment were evaluated in order to interpret the discordant study results. No demographic or disease-related factors enabled identification of a patient subset where Betaseron treatment was predictably associated with delayed progression of disability.

In Studies 2 and 3, like Study 1, a statistically significant decrease in the incidence of relapses associated with Betaseron treatment was demonstrated. In Study 2, the mean annual relapse rates were 0.42 and 0.63 in the Betaseron and placebo groups, respectively ($p < 0.001$). In Study 3, the mean annual relapse rates were 0.16, 0.20, and 0.28, for the fixed dose, surface area-adjusted dose, and placebo groups, respectively ($p < 0.02$).

MRI endpoints in both Study 2 and Study 3 showed lesser increases in T2 MRI lesion area and decreased number of active MRI lesions in patients in the Betaseron groups. The exact relationship between MRI findings and the clinical status of patients is unknown. Changes in MRI findings often do not correlate with changes in disability progression. The prognostic significance of the MRI findings in these studies is not known.

In Study 4, 468 patients who had recently (within 60 days) experienced an isolated demyelinating event, and who had lesions typical of multiple sclerosis on brain MRI were randomized to receive either 0.25 mg Betaseron (N = 292) or placebo (N = 176) subcutaneously every other day (ratio 5:3). The primary outcome measure was time to development of a second exacerbation with involvement of at least two distinct anatomical regions. Secondary outcomes were brain MRI measures, including the cumulative number of newly active lesions, and the absolute change in T2 lesion volume. Patients were followed for up to two years or until they fulfilled the primary endpoint.

Eight percent of subjects on Betaseron and 6% of subjects on placebo withdrew from the study for a reason other than the development of a second exacerbation. Time to development of a second exacerbation was significantly delayed in patients treated with Betaseron compared to placebo ($p < 0.0001$). The Kaplan-Meier estimates of the percentage of patients developing an exacerbation within 24 months were 45% in the placebo group and 28% of the Betaseron group (Figure 2). The risk for developing a second exacerbation in the Betaseron group was 53% of the risk in the placebo group (Hazard ratio = 0.53; 95% confidence interval 0.39 to 0.73).

Figure 2 – Onset of Second Exacerbation by Time on Study (Kaplan-Meier Methodology)

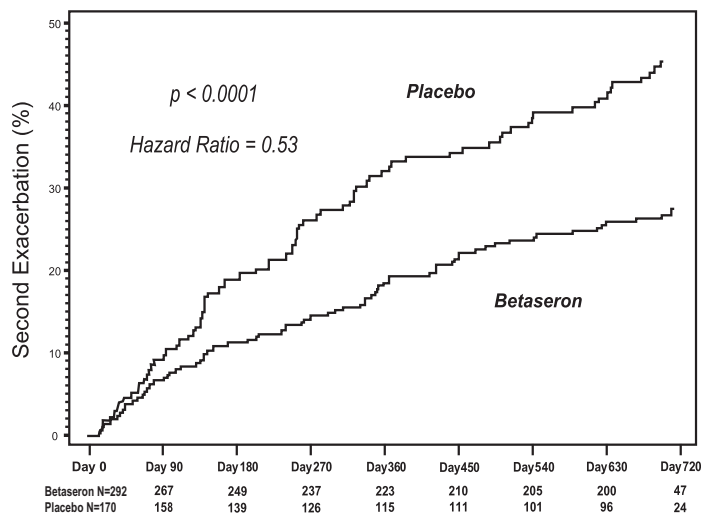

Patients treated with Betaseron demonstrated a lower number of newly active lesions during the course of the study. A significant difference between Betaseron and placebo was not seen in the absolute change in T2 lesion volume during the course of the study.

Safety and efficacy of treatment with Betaseron beyond three years are not known.

INDICATIONS AND USAGE

Betaseron (Interferon beta-1b) is indicated for the treatment of relapsing forms of multiple sclerosis to reduce the frequency of clinical exacerbations. Patients with multiple sclerosis in whom efficacy has been demonstrated include patients who have experienced a first clinical episode and have MRI features consistent with multiple sclerosis.

CONTRAINDICATIONS

Betaseron is contraindicated in patients with a history of hypersensitivity to natural or recombinant interferon beta, Albumin (Human), USP, or any other component of the formulation.

WARNINGS

Depression and Suicide

Betaseron (Interferon beta-1b) should be used with caution in patients with depression, a condition that is common in people with multiple sclerosis. Depression and suicide have been reported to occur with increased frequency in patients receiving interferon compounds, including Betaseron. Patients treated with Betaseron should be advised to report immediately any symptoms of depression and/or suicidal ideation to their prescribing physicians. If a patient develops depression, cessation of Betaseron therapy should be considered.

In the four randomized controlled studies there were three suicides and eight suicide attempts among the 1532 patients in the Betaseron treated groups compared to one suicide and four suicide attempts among the 965 patients in the placebo groups.

Injection Site Necrosis

Injection site necrosis (ISN) has been reported in 4% of patients in controlled clinical trials (see **ADVERSE REACTIONS**). Typically, injection site necrosis occurs within the first four months of therapy, although post-marketing reports have been received of ISN occurring over one year after initiation of therapy. Necrosis may occur at a single or multiple injection sites. The necrotic lesions are typically three cm or less in diameter, but larger areas have been reported. Generally the necrosis has extended only to subcutaneous fat. However, there are also reports of necrosis extending to and including fascia overlying muscle. In some lesions where biopsy results are available, vasculitis has been reported. For some lesions debridement and, infrequently, skin grafting have been required.

As with any open lesion, it is important to avoid infection and, if it occurs, to treat the infection. Time to healing was varied depending on the severity of the necrosis at the time treatment was begun. In most cases healing was associated with scarring.

Some patients have experienced healing of necrotic skin lesions while Betaseron therapy continued; others have not. Whether to discontinue therapy following a single site of necrosis is dependent on the extent of necrosis. For patients who continue therapy with Betaseron after injection site necrosis has occurred, Betaseron should not be administered into the affected area until it is fully healed. If multiple lesions occur, therapy should be discontinued until healing occurs.

Patient understanding and use of aseptic self-injection techniques and procedures should be periodically reevaluated, particularly if injection site necrosis has occurred.

Anaphylaxis

Anaphylaxis has been reported as a rare complication of Betaseron use. Other allergic reactions have included dyspnea, bronchospasm, tongue edema, skin rash and urticaria (see **ADVERSE REACTIONS**).

Albumin (Human), USP

This product contains albumin, a derivative of human blood. Based on effective donor screening and product manufacturing processes, it carries an extremely remote risk for transmission of viral diseases. A theoretical risk for transmission of Creutzfeldt-Jakob disease (CJD) also is considered extremely remote. No cases of transmission of viral diseases or CJD have ever been identified for albumin.

PRECAUTIONS

Information for Patients

All patients should be instructed to carefully read the supplied Betaseron Medication Guide. Patients should be cautioned not to change the dose or schedule of administration without medical consultation.

Patients should be made aware that serious adverse reactions during the use of Betaseron have been reported, including depression and suicidal ideation,

injection site necrosis, and anaphylaxis (see **WARNINGS**). Patients should be advised of the symptoms of depression or suicidal ideation and be told to report them immediately to their physician. Patients should also be advised of the symptoms of allergic reactions and anaphylaxis.

Patients should be advised to promptly report any break in the skin, which may be associated with blue-black discoloration, swelling, or drainage of fluid from the injection site, prior to continuing their Betaseron therapy.

Patients should be informed that flu-like symptoms are common following initiation of therapy with Betaseron. In the controlled clinical trials, antipyretics and analgesics were permitted for relief of these symptoms. In addition, gradual dose titration during initiation of Betaseron treatment may reduce flu-like symptoms (see **DOSAGE AND ADMINISTRATION**).

Female patients should be cautioned about the abortifacient potential of Betaseron (see **PRECAUTIONS, Pregnancy – Teratogenic Effects**).

Instruction on Self-injection Technique and Procedures

Patients should be instructed in the use of aseptic technique when administering Betaseron. Appropriate instruction for reconstitution of Betaseron and methods of self-injection should be provided, including careful review of the Betaseron Medication Guide. The first injection should be performed under the supervision of an appropriately qualified health care professional.

Patients should be cautioned against the re-use of needles or syringes and instructed in safe disposal procedures. A puncture resistant container for disposal of used needles and syringes should be supplied to the patient along with instructions for safe disposal of full containers.

Patients should be advised of the importance of rotating areas of injection with each dose, to minimize the likelihood of severe injection site reactions, including necrosis or localized infection, (see **Picking an Injection Site** section of the **Medication Guide**).

Laboratory Tests

In addition to those laboratory tests normally required for monitoring patients with multiple sclerosis, complete blood and differential white blood cell counts, platelet counts and blood chemistries, including liver function tests, are recommended at regular intervals (one, three, and six months) following introduction of Betaseron therapy, and then periodically thereafter in the absence of clinical symptoms. Thyroid function tests are recommended every six months in patients with a history of thyroid dysfunction or as clinically indicated. Patients with myelosuppression may require more intensive monitoring of complete blood cell counts, with differential and platelet counts.

Drug Interactions

No formal drug interaction studies have been conducted with Betaseron. In the placebo controlled studies in MS, corticosteroids or ACTH were administered for treatment of relapses for periods of up to 28 days in patients (N=664) receiving Betaseron.

Carcinogenesis, Mutagenesis, and Impairment of Fertility

Carcinogenesis: Interferon beta-1b has not been tested for its carcinogenic potential in animals.

Mutagenesis: Betaseron was not mutagenic when assayed for genotoxicity in the Ames bacterial test in the presence or absence of metabolic activation. Interferon beta-1b was not mutagenic to human peripheral blood lymphocytes *in vitro*, in the presence or absence of metabolic inactivation. Betaseron treatment of mouse BALBc-3T3 cells did not result in increased transformation frequency in an *in vitro* model of tumor transformation.

Impairment of fertility: Studies in normally cycling, female rhesus monkeys at doses up to 0.33 mg/kg/day (32 times the recommended human dose based on body surface area, body surface dose based on 70 kg female) had no apparent adverse effects on either menstrual cycle duration or associated hormonal profiles (progesterone and estradiol) when administered over three consecutive menstrual cycles. The validity of extrapolating doses used in animal studies to human doses is not known. Effects of Betaseron on normally cycling human females are not known.

Pregnancy – Teratogenic Effects

Pregnancy Category C: Betaseron was not teratogenic at doses up to 0.42 mg/kg/day when given to pregnant female rhesus monkeys on gestation days 20 to 70. However, a dose related abortifacient activity was observed in these monkeys when Interferon beta-1b was administered at doses ranging from 0.028 mg/kg/day to 0.42 mg/kg/day (2.8 to 40 times the recommended human dose based on body surface area comparison). The validity of extrapolating doses used in animal studies to human doses is not known. Lower doses were not studied in monkeys. Spontaneous abortions while on treatment were reported in patients (n=4) who participated in the Betaseron RRMS clinical trial. Betaseron given to rhesus monkeys on gestation days 20 to 70 did not cause teratogenic effects; however, it is not known if teratogenic effects exist in humans. There are no adequate and well-controlled studies in pregnant women. If the patient becomes pregnant or plans to become pregnant while taking Betaseron, the patient should be apprised of the potential hazard to the fetus and it should be recommended that the patient discontinue therapy.

Nursing Mothers

It is not known whether Betaseron is excreted in human milk. Because many drugs are excreted in human milk and because of the potential for serious adverse reactions in nursing infants from Betaseron, a decision should be made to either discontinue nursing or discontinue the drug, taking into account the importance of drug to the mother.

Pediatric Use

Safety and efficacy in pediatric patients have not been established.

Geriatric Use

Clinical studies of Betaseron did not include sufficient numbers of patients aged 65 and over to determine whether they respond differently than younger patients.

ADVERSE REACTIONS

In all studies, the most serious adverse reactions with Betaseron were depression, suicidal ideation and injection site necrosis (see **WARNINGS**). The incidence of depression of any severity was approximately 30% in both Betaseron-treated patients and placebo-treated patients. Anaphylaxis and other allergic reactions have been reported in patients using Betaseron (see **WARNINGS**). The most commonly reported adverse reactions were lymphopenia (lymphocytes<1500/mm³), injection site reaction, asthenia, flu-like symptom complex, headache, and pain. The most frequently reported adverse reactions resulting in clinical intervention (e.g., discontinuation of Betaseron, adjustment in dosage, or the need for concomitant medication to treat an adverse reaction symptom) were depression, flu-like symptom complex, injection site reactions, leukopenia, increased liver enzymes, asthenia, hypertonia, and myasthenia.

Because clinical trials are conducted under widely varying conditions and over varying lengths of time, adverse reaction rates observed in the clinical trials of Betaseron cannot be directly compared to rates in clinical trials of other drugs, and may not reflect the rates observed in practice. The adverse reaction information from clinical trials does, however, provide a basis for identifying the adverse events that appear to be related to drug use and for approximating rates.

The data described below reflect exposure to Betaseron in the four placebo controlled trials of 1407 patients with MS treated with 0.25 mg or 0.16 mg/m², including 1261 exposed for greater than one year. The population encompassed an age range from 18 – 65 years. Sixty-four percent (64%) of the patients were female. The percentages of Caucasian, Black, Asian, and Hispanic patients were 94.8%, 3.5%, 0.1%, and 0.7%, respectively.

The safety profiles for Betaseron-treated patients with SPMS and RRMS were similar. Clinical experience with Betaseron in other populations (patients with cancer, HIV positive patients, etc.) provides additional data regarding adverse reactions; however, experience in non-MS populations may not be fully applicable to the MS population.

Table 2 enumerates adverse events and laboratory abnormalities that occurred among all patients treated with 0.25 mg or 0.16 mg/m² Betaseron every other day for periods of up to three years in the four placebo controlled trials (Study

1-4) at an incidence that was at least 2.0% more than that observed in the placebo patients (System Organ Class, MedDRA v. 8.0).

Table 2 Adverse Reactions and Laboratory Abnormalities		
System Organ Class MedDRA v. 8.0[#] Adverse Reaction	Placebo (N=965)	Betaseron (N=1407)
Blood and lymphatic system disorders		
Lymphocytes count decreased (< 1500/mm ³) [×]	66%	86%
Absolute neutrophil count decreased (< 1500/mm ³) [×]	5%	13%
White blood cell count decreased (< 3000/mm ³) [×]	4%	13%
Lymphadenopathy	3%	6%
Nervous system disorders		
Headache	43%	50%
Insomnia	16%	21%
Incoordination	15%	17%
Vascular disorders		
Hypertension	4%	6%
Respiratory, thoracic and mediastinal disorders		
Dyspnea	3%	6%
Gastrointestinal disorders		
Abdominal pain	11%	16%
Hepatobiliary disorders		
Alanine aminotransferase increased (SGPT > 5 times baseline) [×]	4%	12%
Aspartate aminotransferase increased (SGOT > 5 times baseline) [×]	1%	4%
Skin and subcutaneous tissue disorders		
Rash	15%	21%
Skin disorder	8%	10%
Musculoskeletal and connective tissue disorders		
Hypertonia	33%	40%
Myalgia	14%	23%
Renal and urinary disorders		
Urinary urgency	8%	11%
Reproductive system and breast disorders		
Metrorrhagia [*]	7%	9%
Impotence ^{**}	6%	8%
General disorders and administration site conditions		
Injection site reaction (various kinds) ⁰	26%	78%
Asthenia	48%	53%
Flu-like symptoms (complex) [§]	37%	57%
Pain	35%	42%
Fever	19%	31%
Chills	9%	21%
Peripheral edema	10%	12%
Chest pain	6%	9%
Malaise	3%	6%
Injection site necrosis	0%	4%
[#] except for "injection site reaction (various kinds) ⁰ " and "flu-like symptom complex [§] " the most appropriate MedDRA term is used to describe a certain reaction and its synonyms and related conditions.		

×	laboratory abnormality
*	pre-menopausal women
**	men
0	"Injection site reaction (various kinds)" comprises all adverse events occurring at the injection site (except injection site necrosis), i.e. the following terms: injection site reaction, injection site hemorrhage, injection site hypersensitivity, injection site inflammation, injection site mass, injection site pain, injection site edema and injection site atrophy.
§	"Flu-like symptom complex" denotes flu syndrome and/or a combination of at least two AEs from fever, chills, myalgia, malaise, sweating.

Injection Site Reactions

In four controlled clinical trials, injection site reactions occurred in 78% of patients receiving Betaseron with injection site necrosis in 4%. Injection site inflammation (42%), injection site pain (16%), injection site hypersensitivity (4%), injection site necrosis (4%), injection site mass (2%), injection site edema (2%) and non-specific reactions were significantly associated with Betaseron treatment (see **WARNINGS** and **PRECAUTIONS**). The incidence of injection site reactions tended to decrease over time. Approximately 69% of patients experienced the event during the first three months of treatment, compared to approximately 40% at the end of the studies.

Flu-Like Symptom Complex

The rate of flu-like symptom complex was approximately 57% in the four controlled clinical trials. The incidence decreased over time, with only 10% of patients reporting flu-like symptom complex at the end of the studies. For patients who experienced a flu-like symptom complex in Study 1, the median duration was 7.5 days.

Laboratory Abnormalities

In the four clinical trials, leukopenia was reported in 18% and 6% of patients in Betaseron- and placebo-treated groups, respectively. No patients were withdrawn or dose reduced for neutropenia in Study 1. Three percent (3%) of patients in Studies 2 and 3 experienced leukopenia and were dose-reduced. Other abnormalities included increase of SGPT to greater than five times baseline value (12%), and increase of SGOT to greater than five times baseline value (4%). In Study 1, two patients were dose reduced for increased hepatic enzymes; one continued on treatment and one was ultimately withdrawn. In Studies 2 and 3, 1.5% of Betaseron patients were dose-reduced or interrupted treatment for increased hepatic enzymes. In Study 4, 1.7% of patients were withdrawn from treatment due to increased hepatic enzymes, two of them after a dose reduction. In Studies 1-4, nine (0.6%) patients were withdrawn from treatment with Betaseron for any laboratory abnormality, including four (0.3%) patients following dose reduction. (see **PRECAUTIONS, Laboratory Tests**).

Menstrual Irregularities

In the four clinical trials, 97 (12%) of the 783 pre-menopausal females treated with Betaseron and 79 (15%) of the 528 pre-menopausal females treated with placebo reported menstrual disorders. One event was reported as severe, all other reports were mild to moderate severity. No patients withdrew from the studies due to menstrual irregularities.

Postmarketing Experience

The following adverse events have been observed during postmarketing experience with Betaseron and are classified within body system categories:

Blood and lymphatic system disorders: Anemia, Thrombocytopenia

Endocrine disorders: Hypothyroidism, Hyperthyroidism, Thyroid dysfunction

Metabolism and nutrition disorders: Hypocalcemia, Hyperuricemia, Triglyceride increased, Anorexia, Weight decrease, Weight increase

Psychiatric disorders: Anxiety, Confusion, Depersonalization, Emotional lability

Nervous system disorders: Ataxia, Convulsion, Dizziness, Paresthesia, Psychotic symptoms

Cardiac disorders: Cardiomyopathy, Palpitations, Tachycardia

Vascular disorders: Deep vein thrombosis, Pulmonary embolism, Vasodilatation

Respiratory, thoracic and mediastinal disorders: Bronchospasm, Pneumonia

Gastrointestinal disorders: Diarrhea, Nausea, Pancreatitis, Vomiting
 Hepatobiliary disorders: Hepatitis, Gamma GT increased
 Skin and subcutaneous tissue disorders: Alopecia, Pruritus, Skin discoloration, Urticaria
 Musculoskeletal and connective tissue disorders: Arthralgia
 Reproductive system and breast disorder: Menorrhagia
 Renal and urinary disorders: Urinary tract infection, Urosepsis
 General disorders and administration site conditions: Fatal capillary leak syndrome*.
 *The administration of cytokines to patients with a pre-existing monoclonal gammopathy has been associated with the development of this syndrome.

Immunogenicity

As with all therapeutic proteins, there is a potential for immunogenicity. Serum samples were monitored for the development of antibodies to Betaseron during Study 1. In patients receiving 0.25 mg every other day 56/124 (45%) were found to have serum neutralizing activity at one or more of the time points tested. In Study 4, neutralizing activity was measured every 6 months and at end of study. At individual visits after start of therapy, activity was observed in 16.5% up to 25.2% of the Betaseron treated patients. Such neutralizing activity was measured at least once in 75 (29.9%) out of 251 Betaseron patients who provided samples during treatment phase; of these, 17 (22.7%) converted to negative status later in the study.

Based on all the available evidence, the relationship between antibody formation and clinical safety or efficacy is not known.

These data reflect the percentage of patients whose test results were considered positive for antibodies to Betaseron using a biological neutralization assay that measures the ability of immune sera to inhibit the production of the interferon-inducible protein, MxA. Neutralization assays are highly dependent on the sensitivity and specificity of the assay. Additionally, the observed incidence of neutralizing activity in an assay may be influenced by several factors including sample handling, timing of sample collection, concomitant medications, and underlying disease. For these reasons, comparison of the incidence of antibodies to Betaseron with the incidence of antibodies to other products may be misleading. Anaphylactic reactions have rarely been reported with the use of Betaseron.

DRUG ABUSE AND DEPENDENCE

No evidence or experience suggests that abuse or dependence occurs with Betaseron therapy; however, the risk of dependence has not been systematically evaluated.

OVERDOSAGE

Safety of doses higher than 0.25 mg every other day has not been adequately evaluated. The maximum amount of Betaseron that can be safely administered has not been determined.

DOSAGE AND ADMINISTRATION

The recommended dose of Betaseron is 0.25 mg injected subcutaneously every other day.

Generally, patients should be started at 0.0625 mg (0.25 mL) subcutaneously every other day, and increased over a six week period to 0.25 mg (1.0 mL) every other day (see Table 3).

Table 3. Schedule for Dose Titration

	Recommended Titration	Betaseron Dose	Volume
Weeks 1-2	25%	0.0625 mg	0.25 mL
Weeks 3-4	50%	0.125 mg	0.50 mL
Weeks 5-6	75%	0.1875 mg	0.75 mL
Week 7+	100%	0.25 mg	1.0 mL

To reconstitute lyophilized Betaseron for injection, attach the prefilled syringe containing the diluent (Sodium Chloride, 0.54% Solution) to the Betaseron vial using the vial adapter. Slowly inject 1.2 mL of diluent into the Betaseron vial. Gently swirl the vial to dissolve the drug completely; do not shake. Foaming may occur during reconstitution or if the vial is swirled or shaken too vigorously. If

foaming occurs, allow the vial to sit undisturbed until the foam settles. Visually inspect the reconstituted product before use; discard the product if it contains particulate matter or is discolored. Keeping the syringe and vial adapter in place, turn the assembly over so that the vial is on top. Withdraw the appropriate dose of Betaseron solution. Remove the vial from the vial adapter before injecting Betaseron. One mL of reconstituted Betaseron solution contains 0.25 mg of Interferon beta-1b/mL.

Betaseron is intended for use under the guidance and supervision of a physician. It is recommended that physicians or qualified medical personnel train patients in the proper technique for self-administering subcutaneous injections. Patients should be advised to rotate sites for subcutaneous injections (see **PRECAUTIONS, Instruction on Self-injection Technique and Procedures**). Concurrent use of analgesics and/or antipyretics may help ameliorate flu-like symptoms on treatment days. Betaseron should be visually inspected for particulate matter and discoloration prior to administration.

Stability and Storage

The reconstituted product contains no preservative. Before reconstitution with diluent, store Betaseron at room temperature 25°C (77°F). Excursions of 15 to 30°C (59 to 86°F) are permitted. After reconstitution, if not used immediately, the product should be refrigerated and used within three hours. Do not freeze.

HOW SUPPLIED

Betaseron is supplied as a lyophilized powder containing 0.3 mg of Interferon beta-1b, 15 mg Albumin (Human), USP, and 15 mg Mannitol, USP. Drug is packaged in a clear glass, single-use vial (3 mL capacity). A pre-filled single-use syringe containing 1.2 mL of diluent (Sodium Chloride, 0.54% solution), two alcohol prep pads, and one vial adapter with attached 30 gauge needle are included for each vial of drug. Betaseron and the diluent are for single-use only. Unused portions should be discarded. Store at room temperature.

NDC # 50419-523-35

14 blister units, 0.3 mg/vial.

Rx Only.

REFERENCES

- Poser CM, et al. Ann Neurol 1983; 13(3): 227-231
 - Kurtzke JF. Neurology 1983; 33(11): 1444-1452
- U.S. Patent No. 4,588,585; 4,961,969; 5,702,699; 6,994,847

PATIENT INFORMATION

Medication Guide Betaseron®

(bay-ta-seer-on)

Interferon beta-1b

(in-ter-feer-on beta-one-be)

Please read this leaflet carefully before you start to use Betaseron® and each time your prescription is refilled since there may be new information. The information in this medication guide does not take the place of talking with your doctor or healthcare professional.

What is the most important information I should know about Betaseron?

Betaseron will not cure multiple sclerosis (MS) but it has been shown to decrease the number of flare-ups of the disease. Betaseron can cause serious side effects, so before you start taking Betaseron, you should talk to your doctor about the possible benefits of Betaseron and its possible side effects to decide if Betaseron is right for you. Potential serious side effects include:

- Depression.** Some patients treated with interferons, including Betaseron, have become seriously depressed (feeling sad). Some patients have thought about or have attempted to kill themselves. Depression (a sinking of spirits or sadness) is not uncommon in people with multiple sclerosis. However, if you are feeling noticeably sadder or helpless, or feel like hurting yourself or others, you should tell a family member or friend right away and call

your doctor or health care provider as soon as possible. Your doctor may ask that you stop using Betaseron. Before starting Betaseron, you should also tell your doctor if you have ever had any mental illness, including depression, and if you take any medications for depression.

- **Risk to pregnancy.** If you become pregnant while taking Betaseron you should stop using Betaseron immediately and call your doctor. Betaseron may cause you to lose your baby (miscarry) or may cause harm to your unborn child. You and your doctor will need to decide whether the potential benefit of taking Betaseron is greater than the potential risks to your unborn child.
- **Allergic reactions.** Some patients taking Betaseron have had severe allergic reactions leading to difficulty breathing and swallowing; these reactions can happen quickly. Allergic reactions can happen after your first dose or may not happen until after you have taken Betaseron many times. Less severe allergic reactions such as rash, itching, skin bumps or swelling of the mouth and tongue can also happen. If you think you are having an allergic reaction, stop using Betaseron immediately and call your doctor.
- **Injection site problems.** Betaseron may cause redness, pain or swelling at the place where an injection was given. A few patients have developed skin infections or areas of severe skin damage (necrosis). If one of your injection sites becomes swollen and painful or the area looks infected and it doesn't heal within a few days, you should call your doctor.

What is Betaseron?

Betaseron is a type of protein called beta interferon that occurs naturally in the body. It is used to treat relapsing forms of multiple sclerosis. It will not cure your MS but may decrease the number of flare-ups of the disease. MS is a lifelong disease that affects your nervous system by destroying the protective covering (myelin) that surrounds your nerve fibers. The way Betaseron works in MS is not known.

Who should not take Betaseron?

Do not take Betaseron if you:

- Have had allergic reactions such as difficulty breathing, flushing or hives to another interferon beta or to human albumin.

If you have any of the following conditions or serious medical problems, you should tell your doctor *before* taking Betaseron:

- Depression (a sinking feeling or sadness), anxiety (feeling uneasy, nervous, or fearful for no reason), or trouble sleeping
- Liver diseases
- Problems with your thyroid gland
- Blood problems such as bleeding or bruising easily and anemia (low red blood cells) or low white blood cells
- Epilepsy
- Are pregnant, breast feeding, or planning to become pregnant

You should tell your doctor if you are taking any other prescription or non-prescription medicines. This includes any vitamin or mineral supplements, or herbal products.

How should I take Betaseron?

Betaseron is given by injection under the skin (subcutaneous injection) every other day. Your injections should be approximately 48 hours (two days) apart, so it is best to take them at the same time each day, preferably in the evening just before bedtime.

You may be started on a lower dose when you first start taking Betaseron. Your doctor will tell you what dose of Betaseron to use, and that dose may change based on how your body responds. You should not change your dose without talking with your doctor.

If you miss a dose, you should take your next dose as soon as you remember or are able to take it. Your next injection should be taken about 48 hours (two

days) after that dose. **Do not take Betaseron on two consecutive days.** If you accidentally take more than your prescribed dose, or take it on two consecutive days, call your doctor right away.

You should always follow your doctor's instructions and advice about how to take this medication. If your doctor feels that you, or a family member or friend may give you the injections, then you and/or the other person should be trained by your doctor or healthcare provider in how to give an injection. Do not try to give yourself (or have another person give you) injections at home until you (or both of you) understand and are comfortable with how to prepare your dose and give the injection.

Always use a new, unopened, vial of Betaseron and syringe for each injection. Never reuse vials or syringes.

It is important that you change your injection site each time Betaseron is injected. This will lessen the chance of your having a serious skin reaction at the spot where you inject Betaseron. You should always avoid injecting Betaseron into an area of skin that is sore, reddened, infected or otherwise damaged.

At the end of this leaflet there are detailed instructions on how to prepare and give an injection of Betaseron. You should become familiar with these instructions and follow your doctor's orders before injecting Betaseron.

What should I avoid while taking Betaseron?

- **Pregnancy.** You should avoid becoming pregnant while taking Betaseron until you have talked with your doctor. Betaseron can cause you to lose your baby (miscarry).
- **Breast feeding.** You should talk to your doctor if you are breast feeding an infant. It is not known if the interferon in Betaseron can be passed to an infant in mother's milk, and it is not known whether the drug could harm the infant if it is passed to an infant.

What are the possible side effects of Betaseron?

- **Flu-like symptoms.** Most patients have flu-like symptoms (fever, chills, sweating, muscle aches and tiredness). For many patients, these symptoms will lessen or go away over time. You should talk to your doctor about whether you should take an over the counter medication for pain or fever reduction before or after taking your dose of Betaseron.
- **Skin reactions.** Soreness, redness, pain, bruising or swelling may occur at the place of injection. (**see "What is the most important information I should know about Betaseron?"**).
- **Depression and anxiety.** Some patients taking interferons have become very depressed and/or anxious. There have been patients taking interferons who have had thoughts about killing themselves. If you feel sad or hopeless you should tell a friend or family member right away and call your doctor immediately. (**see "What is the most important information I should know about Betaseron?"**).
- **Liver problems.** Your liver function may be affected. Symptoms of changes in your liver include yellowing of the skin and whites of the eyes and easy bruising.
- **Blood problems.** You may have a drop in the levels of infection-fighting white blood cells, red blood cells, or cells that help you form blood clots. If drops in levels are severe, they can lessen your ability to fight infections, make you feel tired or sluggish or cause you to bruise or bleed easily.
- **Thyroid problems.** Your thyroid function may change. Symptoms of changes in the function of your thyroid include feeling cold or hot much of the time or change in your weight (gain or loss) without a change in your diet or amount of exercise you are getting.
- **Allergic reaction.** Some patients have had hives, rash, skin bumps or itching while they were taking Betaseron. There is also a rare possibility that you can have a life-threatening allergic reaction. (**see "What is the most important information I should know about Betaseron?"**).

Whether you experience any of these side effects or not, you and your doctor should periodically talk about your general health. Your doctor may want to monitor you more closely and ask you to have blood tests done more frequently.

General Information About Prescription Medicines

Medicines are sometimes prescribed for purposes other than those listed in a Medication Guide. This medication has been prescribed for your particular medical condition. Do not use it for another condition or give this drug to anyone else. If you have any questions you should speak with your doctor or health care professional. You may also ask your doctor or pharmacist for a copy of the information provided to them with the product. Keep this and all drugs out of the reach of children.

Instructions for Preparing and Giving Yourself an Injection of Betaseron

1. Find a clean, flat working surface that is well-lit and collect all the supplies you will need to give yourself an injection. You will need:
One tray containing Betaseron. Make sure the tray contains:
 - A pre-filled diluent syringe with yellow label
 - A vial of Betaseron
 - Two (2) alcohol prep pads
 - A blue vial adapter with a 30 gauge needle attached (in the blister pack)
 - A puncture-resistant sealable container to dispose of used syringes/needles
2. Check the expiration date on the tray label to make sure that it has not expired. **Do not use it if the medication has expired.**
3. Wash your hands thoroughly with soap and water.
4. Open the tray by peeling off the label and take out all the contents. Make sure the blister pack containing the vial adapter is sealed. Check to make sure the rubber cap on the diluent syringe is firmly attached.
5. Turn the tray over, place the Betaseron vial in the well (vial holder) and place the prefilled diluent syringe in the U-shaped trough.

Reconstituting Betaseron

1. Remove the Betaseron vial from the well and take the cap off the vial.
2. Place the vial back into the vial holder. Use an alcohol prep pad to clean the top of the vial. Move the prep pad in one direction. Leave the alcohol prep pad on top of the vial until step 4.
3. Peel the label off the blister pack with the vial adapter in it, but do not remove vial adapter. The vial adapter is sterile; avoid touching the vial adapter.
4. Remove the alcohol prep pad from the top of the Betaseron vial. Keeping the vial adapter in the blister pack, place the adapter on top of the Betaseron vial and push down on the adapter until it pierces the rubber top of the Betaseron vial and snaps in place (**Figure 1**). Remove the blister packaging from the vial adapter.

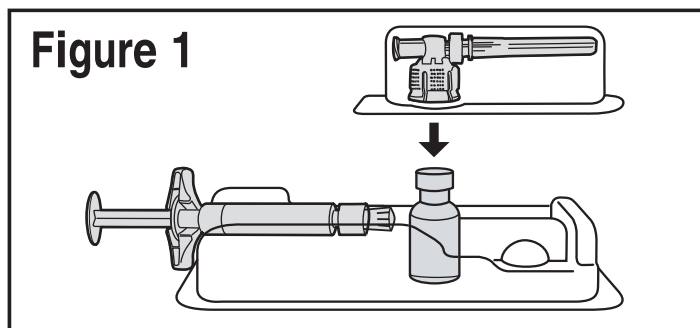

5. Remove the rubber cap from the diluent syringe using a twist and pull motion. Discard the rubber cap.
6. Remove the vial with the vial adapter attached from the tray. Be careful not to pull the vial adapter off the top of the vial.
7. Connect the syringe with the yellow label to the vial adapter by turning clockwise and tighten carefully. This will form the syringe assembly (**Figure 2**).

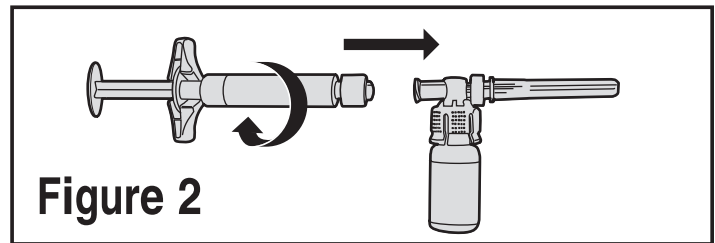

8. Slowly push the plunger of the diluent syringe all the way in. This will transfer all of the diluent in the syringe to the Betaseron vial (**Figure 3**). Continue to hold the plunger in during the mixing process; otherwise the plunger may return to its original position after you release it.

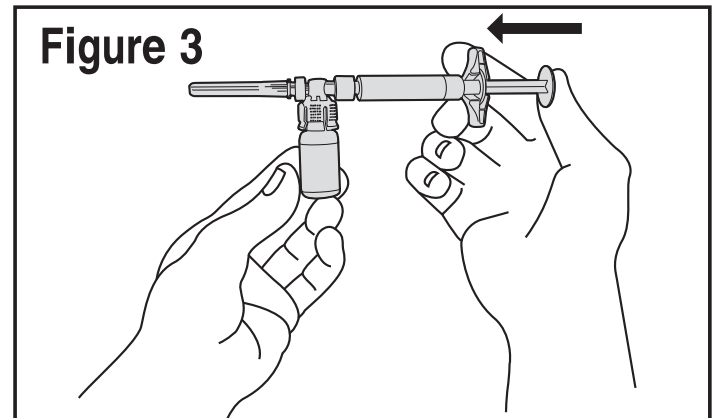

9. Gently swirl the vial to completely dissolve the white cake of Betaseron. Do not shake. Shaking can cause Betaseron to foam; even gently mixing the solution can cause foaming. If there is foam, allow the vial to sit undisturbed until the foam settles.
10. After the cake is dissolved, look closely at the solution to make sure the solution is clear and colorless and does not contain particles. If the mixture contains particles, or is discolored, do not use. Repeat the steps to prepare your dose using a new tray of Betaseron, prefilled syringe, vial adapter and alcohol prep pads. Contact Bayer HealthCare Pharmaceuticals Inc. at 1-800-788-1467 to obtain replacement product.

Preparing the Injection

You have completed the steps to reconstitute your Betaseron and are ready for the injection. The injection should be given immediately after mixing and allowing any foam in the solution to settle. If you must delay giving yourself the injection, you may refrigerate the solution and use within three hours of reconstitution. Do not freeze.

1. With your thumb still pushing the plunger, turn the syringe assembly so that the vial is on top. (The syringe is horizontal.)

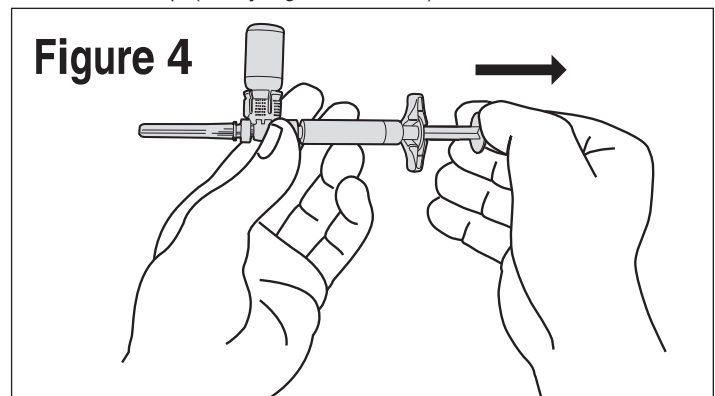

2. Slowly pull the plunger back to withdraw the entire contents of the Betaseron vial into the syringe. (**Figure 4**).

NOTE: The syringe barrel is marked with numbers from 0.25 to 1.0 mL. If the solution in the vial cannot be drawn up to the 1.0 mL mark, discard the vial and

syringe and start over with a new tray containing a Betaseron vial, prefilled diluent syringe, vial adapter and alcohol prep pads.

3. Turn the syringe assembly so that the needle end is pointing up. Remove any air bubbles by tapping the outer wall of the syringe with your fingers. Slowly push the plunger to the 1.0 mL mark on the syringe (or to the amount prescribed by your doctor).

NOTE: If too much solution is pushed into the vial, repeat steps 1, 2, and 3.

4. Turn the syringe assembly so that the vial is at the bottom. Remove the blue vial adapter and the vial from the syringe by twisting the vial adapter as shown in Figure 5. This will remove the vial adapter and the vial from the syringe, but will leave the needle on the syringe (Figure 5).

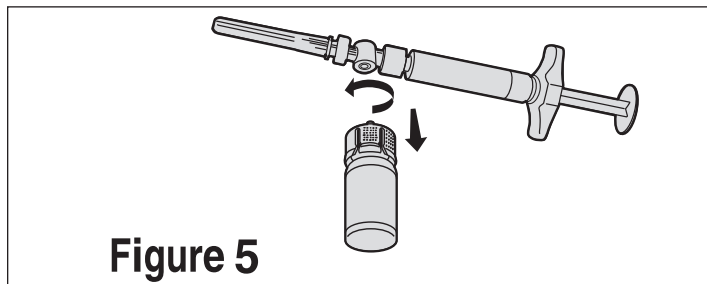
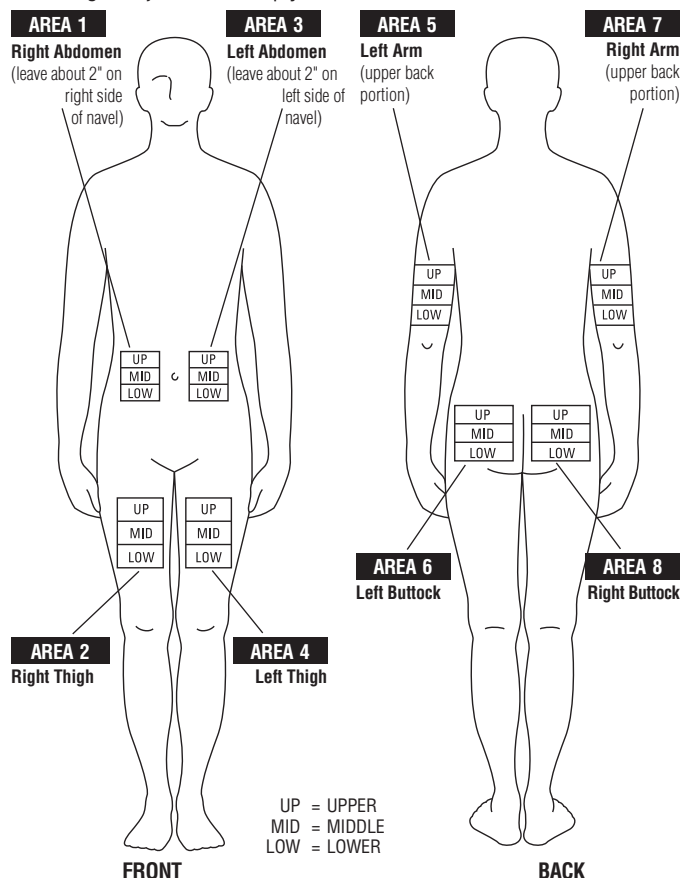

Figure 5

Picking an Injection Site

Betaseron (Interferon beta-1b) is injected under the skin and into the fat layer between the skin and the muscles (subcutaneous tissue). The best areas for injection are where the skin is loose and soft and away from the joints, nerves, and bones. Do not use the area near your navel or waistline. If you are very thin, use only the thigh or outer surface of the arm for injection.

You should pick a different site each time you give yourself an injection. The diagrams show different areas for giving injections. You should not choose the same area for two injections in a row. Keeping a record of your injections will help make sure you rotate your injection sites. You should decide where your injection will be given before you prepare your syringe for injection. If there are any sites that are difficult for you to reach, you can ask someone who has been trained to give injections to help you.



Do not inject in a site where the skin is red, bruised, infected, or scabbed, has broken open, or has lumps, bumps, or pain. Tell your doctor or healthcare provider if you find skin conditions like the ones mentioned here or any other unusual looking areas where you have been given injections.

Using a circular motion, and starting at the injection site and moving outward, clean the injection site with an alcohol wipe. Let the skin area dry before you inject the Betaseron.

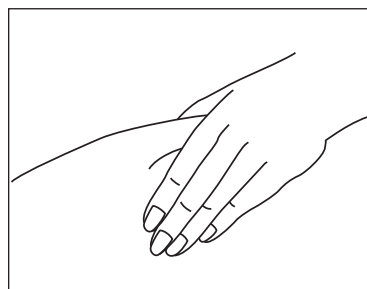

Remove the cap from the needle. Hold the syringe like a pencil or dart in one hand.

Gently pinch the skin around the site with the thumb and forefinger of the other hand.

While holding your skin, stick the needle straight into the skin at a 90° angle with a quick, firm motion.

Once in your skin, slowly pull back on the plunger. If blood appears in the syringe it means that you have entered a blood vessel. Do not inject Betaseron. Withdraw the needle and repeat the steps to prepare your dose. Choose and clean a new injection site. You should not use the same syringe; discard it in your puncture-proof container.

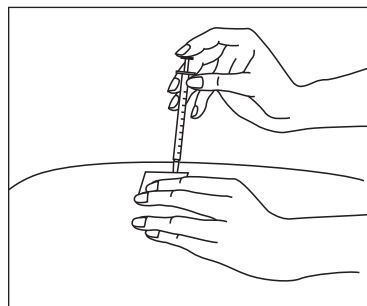

If no blood appears, slowly push the plunger all the way in until the syringe is empty.

Remove the needle from the skin; then place a dry cotton ball or gauze pad over the injection site. Gently massage the injection site for a few moments with the dry cotton ball or gauze pad.

Throw away the syringe in the disposal container.

Disposing of syringes and needles

Used needles and syringes may be placed in a container made specially for disposing of used syringes and needles (called a “Sharps” container), or a hard plastic container with a screw-on cap or metal container with a plastic lid labeled “Used Syringes”. Do not use glass or clear plastic containers. You should always check with your healthcare provider for instructions on how to properly dispose of used vials, needles and syringes. You should follow any special state or local laws regarding the proper disposal of needles and syringes.

DO NOT throw the needle or syringe in the household trash or recycle.

Always keep the disposal container out of the reach of children.

How Should I Store Betaseron?

Betaseron should be stored at room temperature 25°C (77°F). Excursions of 15 to 30°C (59 to 86°F) are permitted. Do not freeze.

This Medication Guide has been approved by the U.S. Food and Drug Administration



Bayer HealthCare Pharmaceuticals

Manufactured by:
Bayer HealthCare Pharmaceuticals Inc.
Montville, NJ 07045

© 2008 Bayer HealthCare Pharmaceuticals Inc.
All rights reserved.
Part Number 6700502
U.S. License No. 1778

Revision Date 4/08